

[The Gallery](#)

[Gallery plan](#)

[Services](#)

[Conditions of hire](#)

[Directions](#)



# The Coningsby Gallery

## *Information Pack 2024/2025*



## About The Gallery

Established in 1994, The Coningsby Gallery (the "Gallery") is excellently located at 30 Tottenham Street, London W1, in the thriving area of Fitzrovia (West Bloomsbury) with Charlotte Street just round the corner - right in the heart of London's cultural West End. The area is renowned for its visual and performing arts, literary connections, museums, leading hotels and excellent shops and boutiques.

The Gallery is available to hire (inclusive or exclusive of the Gallery's own marketing and other services) exhibitions. Many galleries, curators, dealers, individual artists, groups of artists and academic institutions have worked with us/via us since 1994, and many do so quite regularly. We also have a highly developed area of speciality representing a highly diverse range of leading illustrators and other graphic artists whose work is at the art end of the spectrum. We have developed our own databases of clients since 1994 and the databases comprise some 7500 individuals.

We are always keen to review submissions of work and to receive enquiries. Please feel free to contact Andrew Coningsby via [info@coningsbygallery.com](mailto:info@coningsbygallery.com) or 07884 314361.

The Gallery is a welcoming, highly contemporary and 'light' space which attracts a high level of discerning passing trade as well as many regular visitors. Many artists and art dealers/curators use the Gallery as their venue of choice in the West End. The Gallery has a very large picture window to the street that affords passers-by a clear view into the ground floor Gallery. The Gallery has exterior flood lighting and rails around the frontage. Photos of the exterior and interior of the Gallery can be viewed at <https://www.coningsbygallery.com/the-space>.

The Gallery offers three exceptional display rooms with excellent natural light. The three, purpose built, adjoining, open-plan display rooms together offer circa 1,500 square feet of exhibition space. The rear ground floor display room has five lockable illuminated glass-fronted display cabinets and a large atrium skylight. Some interior stair risers and

some atrium surfaces are mirror surfaced which enhances the overall quality of light and feeling of space. A third adjoining display room is situated below ground floor. (Please note that during weekdays, but excluding Private View evenings, part of this lower ground room may be occupied by staff, therefore, unless arranged otherwise with the Gallery, no free-standing 3D artworks are permitted in this space. However, wall hung works are welcome and this room usually comprises part of all exhibitions).

A picture rail hanging system with transparent Perlon cables is in situ to enable secure and flexible wall hanging. No other form of hanging is permitted unless pre-agreed in writing. No other adhesive materials are permitted on the walls (except White-tac or particular kinds of light tac Avery labels – details are provided further down this document) without prior consultation with and written permission from the Gallery.

There are three easels and five plinths available for use.

The gallery has two internet enabled TV's which will also play from a memory stick or from a laptop connected with an HDMI cable. The gallery has two HDMI cables.

A two speaker bluetooth sound system is available. It will play music from any bluetooth device. The sound system also has a portable bluetooth microphone for talks and speeches.

If you plan to use a vinyl name and/or exhibition title sticker on the inside of the picture window to street, please ensure that it is of a peel off/easily removable type so that the glass is not scratched. If any kind of scraper is used to remove the vinyl/window transfer it must be a soft plastic kind of scraper. The Gallery has previously worked with several vinyl/window transfer makers who can advise, custom make and fit the vinyls/transfers: please do not hesitate to ask us for their contact details.

The Gallery has a small kitchenette comprising of a sink, fridge microwave, tea making facilities, basic crockery, serving bowls and vases. There is also a toilet with hand basin and space to hang coats.

The Gallery

Gallery plan

Services

Conditions of hire

Directions



Ground floor Gallery



Features of the Gallery



The Gallery

Gallery plan

Services

Conditions of hire

Directions



Lower ground floor Gallery



Lower ground floor Gallery

# Floor plans, measurements and hanging system

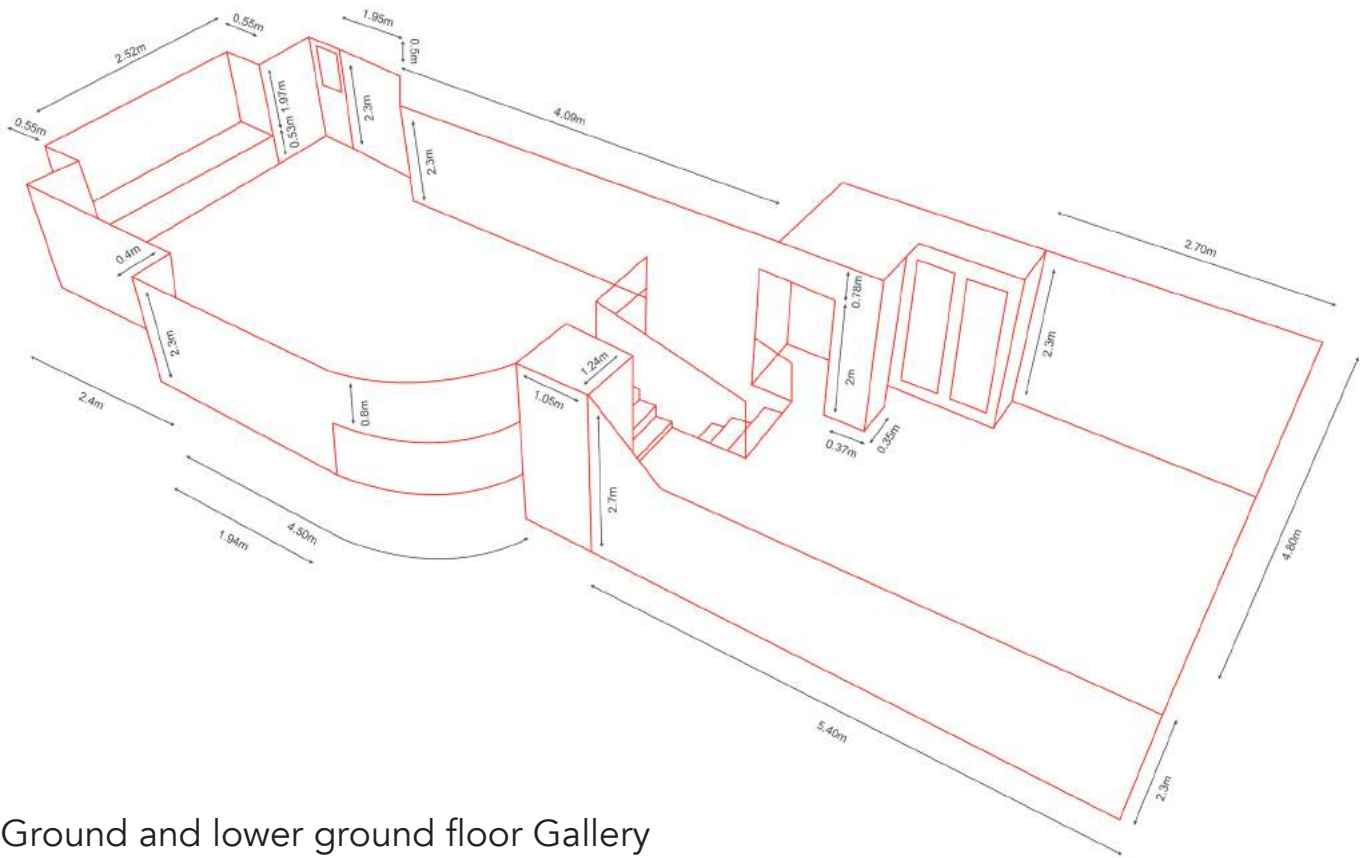

Ground and lower ground floor Gallery

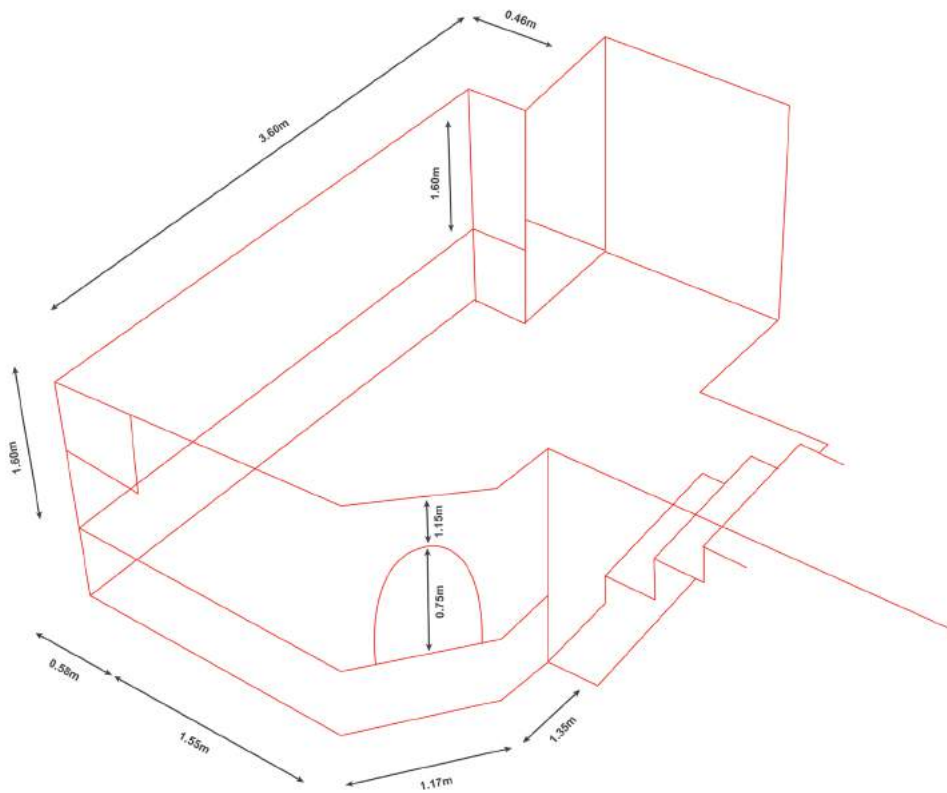

Below ground floor Gallery

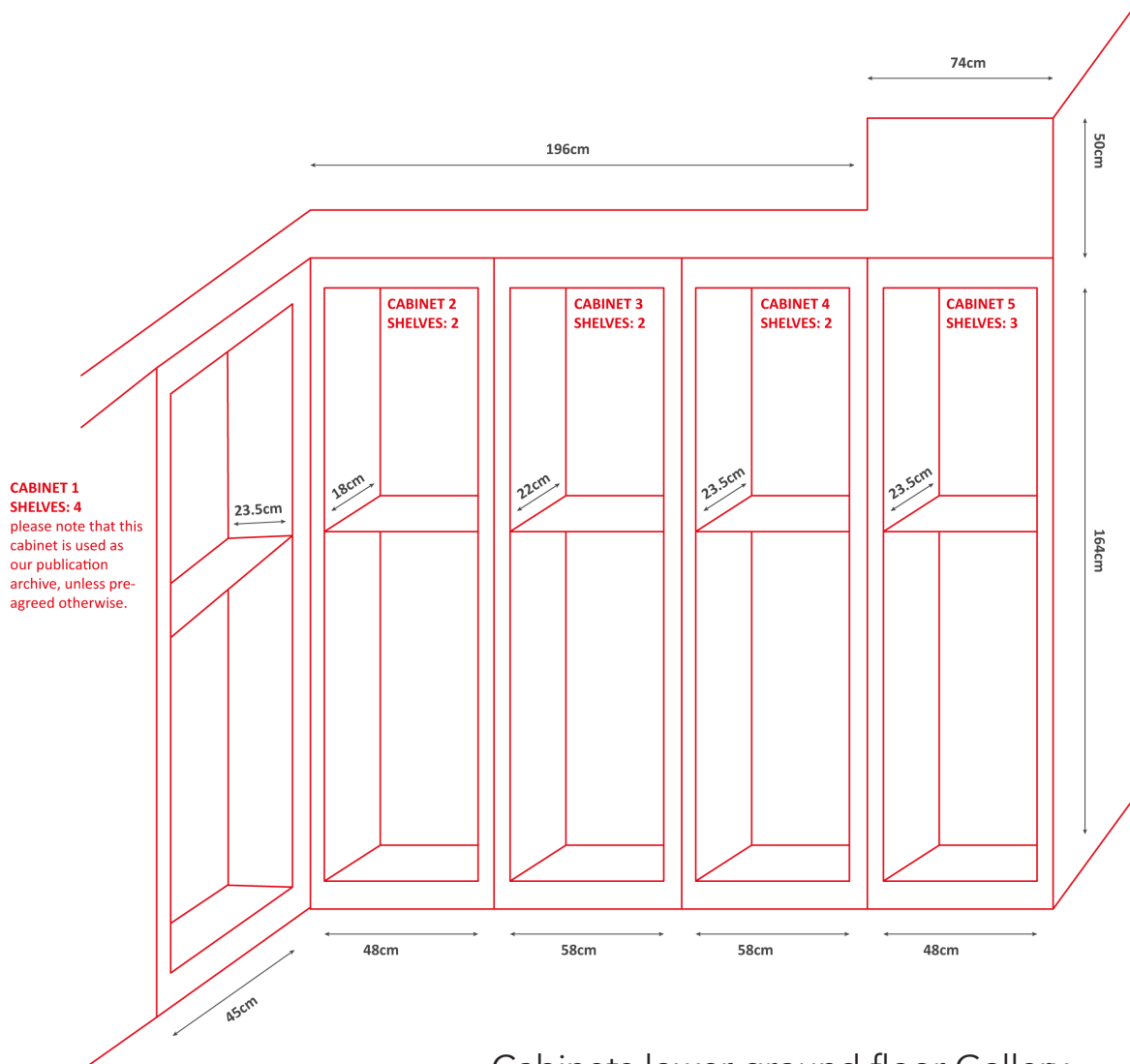

Cabinets lower ground floor Gallery

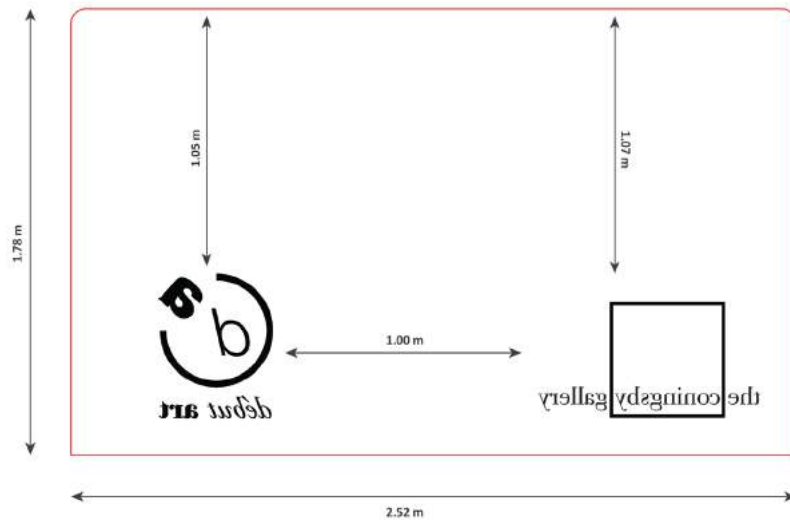

Front window

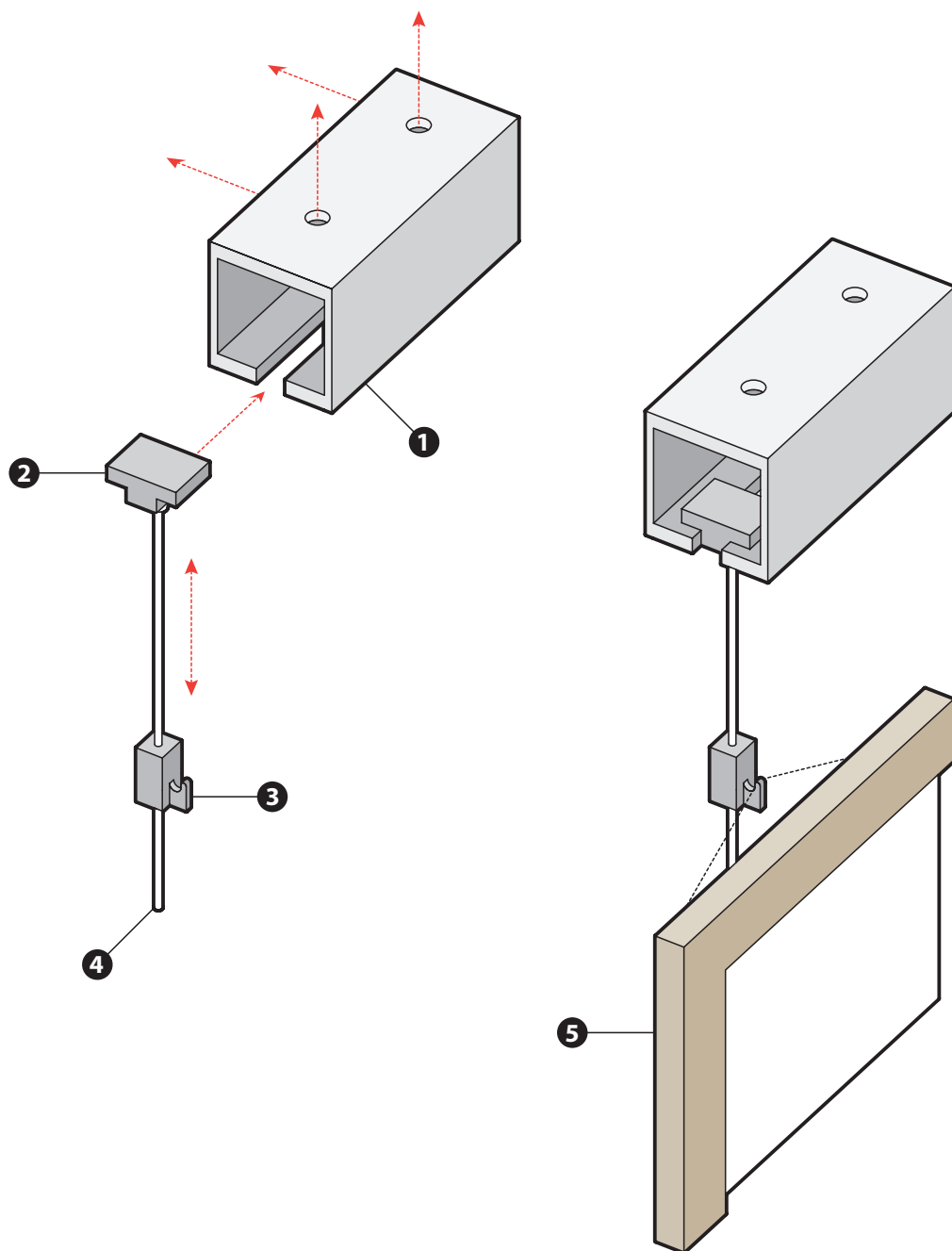

1. Metal rail

2. We have a range of T-shape and cylindrical fittings, which either slide or twist into place. Both can move along the rail. Only the unpainted rails take the cylindrical fixtures.

3. Adjustable hook, which moves up and down the Perlon cables and can accommodate medium sized D-rings, picture wire, mirror plates etc.

4. Perlon cables can take a maximum of 10kg on each cable. For heavier items, we advise distributing between two, possible three cables.

5. Placement of D-rings for larger artworks is advised to be placed a couple of inches from the top, to avoid tilting.



## Services

### **Exhibition arrangement options for exhibiting artists.**

The Gallery offers a wide range of different exhibition and marketing level options for galleries, curators, dealers, individual artists, groups of artists, other galleries, curators, dealers, and academic institutions. Details of the two main standard packages are available below. The standard packages are often negotiable to better accommodate the interests of particular exhibitors. Please feel free to confirm interest in particular packages and services by emailing [info@coningsbygallery.com](mailto:info@coningsbygallery.com).

### **Gallery Hire with services, including PR & other marketing support.**

The Gallery's standard hire charge rates for exhibitions in 2024 and 2025 are £2,760 + VAT for a one week exhibition and £4,968 + VAT for a two week exhibition. No Gallery commission on sales, unless otherwise stated in an invoice. These standard rates are negotiable at the Gallery's sole discretion. We do frequently offer discounts to students and groups of students. If you are interested in a longer show, we can discuss rates.

The items below are included within the prices above.

A two stage e-press release campaign (text and images) to around 160 arts journalists, email invitations to our own database of about 1000 private clients, email invitations to our own database of about 7500 leading commercial commissioning clients worldwide incl. many 'institutions' (at our sole discretion), display of copy/text and up to 24 artworks for the exhibition on <http://www.coningsbygallery.com>, a listing in Galleries Magazine and various listings on arts related web sites.

Free use of the Gallery's card payment machine (Credit card providers deduct transaction charges of 1% - 4.75%. Debit card providers deduct a maximum transaction charge of 60p. Increasing numbers of exhibitors choose to use their own wireless cardpayment machine, such as an iZettle. If exhibitors prefer to use the Gallery's card machine please note that, if the exhibitor wishes. the Gallery Accounts team can produce and supply a statement of account regarding sales or other items of 'paperwork.' Such

exhibitors must issue one consolidated fully itemized overall invoice to the Gallery after the end of each exhibition with full details of each sale that was handled by the Gallery. The Gallery reserves a right to require pre-payment of an additional amount for provision of statements of account and other paperwork and such amounts may range in price from £50 + VAT - £500 + VAT depending on the extent of the work requested and provided. One member of the Gallery team to be on hand to help during one evening Private View until 8.30pm at latest.

Invigilation of the Gallery by a Gallery team member Mondays – Fridays 9.45pm – 5.45pm is at the Gallery's sole discretion and subject to availability of team, if an exhibitor is unable to invigilate.

Free use of Gallery wi-fi.

Free use of the kitchen area.

Free extended opening hours (until 9pm) in the evenings (Mon-Fri) if invigilation is conducted by the exhibitor.

We can supply contact details for many different types of supplier who have helped exhibitors with exhibitions here in the past. These include drinks suppliers, framers, catering companies, window vinyl/window transfer makers

Re: items for the Press Release and display on [www.coningsbygalleries.com](http://www.coningsbygalleries.com) - Please submit relatively finalised text for the Press Release and Gallery web site. Only fairly minimal re-writing (up to 1 hour of work) will be conducted by the Gallery within the pre-agreed Gallery hire rate. Additional time to finalise text for Press Release (or text for use on the Gallery web site) may be charged at a rate of £40 per hour + VAT. The specification for images supplied to us must please be as follows: each image no less than 800 pixels on shortest side (maximum 1200 pixels on shortest side), all images at 300dpi, RGB, JPEG's set at maximum image quality.

All exhibitions may remain displayed in the 'Past Exhibitions' section of the Gallery site, unlimited over time.

A non-refundable/non-transferable deposit of 50% + VAT of the total amount invoiced is usually required within 14 days of issue of a confirmation of reservation invoice and the final 50% +VAT three months before start of exhibition and, in any event, the final 50% must please be paid before start of any marketing or PR or other kind of work by the gallery related to the exhibition. The two payments, combined, secure your exhibition dates. If payment 'due by' dates aren't met, the exhibition may be cancelled at the Gallery's sole discretion.

All payments should be made in UK Pounds Sterling only (unless otherwise pre-agreed) bank transfer directly to the Gallery. All invoices from the Gallery display the Gallery's bank account details. In the unlikely event that The Gallery has to cancel an exhibition, the Gallery will reimburse the exhibitor the monies paid. However, the Gallery does not accept responsibility for loss of earnings or other costs arising from the cancellation by a booking entity.

### **Exhibitions for artists on a full representation basis, inclusive of PR & other marketing support.**

The Gallery is always particularly pleased to hear from further original fine artists and highly artistic illustrators and graphic artists who are seeking full representation.

All PR & marketing support detailed above in this document is provided for artists exhibiting with us on a full representation basis but with extensive curatorial input and with additional PR and marketing support items. Additional PR and marketing support items to be pre-agreed in writing. The additional cost items detailed above in this document are generally not charged by the Gallery for exhibitors having exhibitions on a 'full representation by Gallery' basis. However, the Gallery may require a £500 + VAT refundable deposit advance from the exhibitor against the Gallery's agreed sales % percentage of the proceeds of sales. Gallery commission rates on sales vary per exhibition and are usually between 30% and 50%. All works for sale in full

representation exhibitions must have 20% VAT included in the overall price. Gallery handles all billing to clients, the taking of all purchase payments and issuing of all sales receipts etc. Exhibitors handle packing and shipping of works. Exhibitors must remove all exhibited works at the end of their exhibition. The Gallery has limited storage space. All price information on display during exhibitions must detail that the prices displayed do not include packing and shipping and that such costs will be invoiced to purchaser separately after dispatch.

### **Works for sale in the Gallery's online shop.**

Selected artworks by any exhibiting artist selected by the Gallery for online sales can be made available for sale via the Gallery on its web site.

For artists not exhibiting in the physical Gallery, the Gallery may make a charge to mount the work on the site. The charging amount shall be pre-agreed in writing between the Gallery and exhibitor. All works for sale in the online shop must have 20% VAT included within the overall price. Gallery reserves the right to delete works for sale from its online shop at any time. Gallery and exhibitor to pre-agree in writing a sales commission rate due to the Gallery re: each work for sale in the online shop before each work is made available for sale on the site. Gallery will handle all purchase and payments matters re: all sales via the online shop.

### **Use of the Gallery's card payment machine.**

If you decide to use the Gallery's card payment machine but not to handle all invoicing etc to purchasers yourself (in other words to have the Gallery handle invoicing etc), please let us know as soon as possible. For this service we require that all sales are made through the Gallery card machine and that all sales are subject to a minimum 30% Gallery commission.

Please note that, if you select the option above re: artworks for sale in the Gallery's online shop (namely use of Gallery card payment machine and with Gallery issuing in-voices and receipts etc), you will have to take account of the 30%

Gallery commission



when setting the overall artwork prices and include 20% VAT within the overall on-the-wall/on price list overall price of each artwork and accommodate the fact that credit card providers may deduct 1%-4.75% of the total overall on-the-wall price.

Please also note that, if you wish to use the Gallery's card machine but decide to yourself handle the issue of all receipts and invoices etc, the Gallery would not charge any commission on sales but Gallery would reserve its right to require pre-payment of an additional amount for provision of statements of account and other paperwork and that such amounts range in price from £50 + VAT - £500 + VAT depending on the extent of the work requested and provided.

The arrangements above only relate in circumstances regarding which no higher overall exhibition commission rate has been pre-agreed (for example relating to full representation exhibitions)

If you would like advice regarding pricing your work, please ask Andrew Coningsby or Jonathan Hedley. They will be happy to help. Please note that if you would like to use the card payment facility, all payments can only go to The Gallery. The Gallery will make full pre-agreed payment to you in respect of all cleared funds no more than 45 days after end of your exhibition. At the Gallery's sole discretion debit card payments received may be paid considerably before 45 days have elapsed from end of the exhibition but the Gallery may make a pre-agreed accounting administration charge of £50 + VAT - £250 + VAT for this time/ service.

### **Hanging your exhibition.**

If you need assistance with hanging your work, you may be charged an additional fee of £30 + VAT per hour. This service is at the Gallery's sole discretion and is generally only available Mondays – Fridays, 10.45am – 5.45pm

### **Extra opening hours.**

One Private View is included within the "Gallery Hire with services" exhibition option

detailed above. Gallery staffing for additional Private View functions is generally charged at £30 + VAT per hour and a maximum of two Private Views are permissible for a one week exhibition or three Private Views for a two week exhibition.

## Standard exhibition terms for 2024 – 2025

Please read this information carefully. These Standard Exhibition Terms clearly set out the booking conditions with a list of your responsibilities and commitments for renting and exhibiting at the Gallery, unless otherwise agreed in writing. Where the terms in the invoice or these Standard Exhibition Terms conflict, the terms in the invoice shall prevail.

### Content of work.

The Gallery maintains a reputation for high quality and tasteful exhibitions, therefore reserving the right to refuse any exhibits we feel are unsuitable.

Images the Gallery considers “artistic” nudity will be considered, but any depiction of sexual acts or graphic and pornographic content is not permitted. Equally, material which is demeaning to women, racist, offensive to religious beliefs, homophobic, supports extreme political views or denigrates older or disabled people is unacceptable or any other protected characteristics.

Exhibitors are expected to behave in a reasonable and responsible manner and to ensure that associates and friends also do so. The Gallery will not tolerate any form of physical or verbal abuse towards staff, and individuals who are, or appear to be, under the influence of alcohol or drugs etc will be asked to leave. In the event that this necessitates the closure of an exhibition, the Gallery will not refund any hire costs.

### Gallery hours

Opening hours for exhibitors and the general public:

Monday to Friday: 9.00am – 6.00pm

## Private View

Private Views may only be held Monday – Thursday unless expressly pre-agreed by the Gallery.

Private Views are usually held on the first Tuesday of a one week duration exhibition or on the first Thursday of a two week duration exhibition: 6.00pm – 8.30pm or 6.30pm – 9.00pm

Saturday and Sunday (if applicable):

To be invigilated by exhibitor(s) only: 11.00am – 6.00pm.

The Gallery can accommodate up to approximately 125 people at any one time for a Private View (PV) evening. Each exhibition booking includes one free PV evening with one member of the Gallery team in attendance to help until 8.30/9.00pm.

No Private View must go over the allocated two and a half hours, otherwise exhibitors are subject to an overtime charge of £40 + VAT per hour. Any additional Private View or evening functions at the Gallery are subject to a further charge by the Gallery. After hours functions cannot be held on Mondays or Fridays without prior written agreement. You are permitted to start setting up a drinks bar from 5.00pm in the lower ground floor Gallery on the day of your Private View. Please help the Gallery team member to clear up and clean at the end of your Private View.

Bar staff are to be organised and provided separately by all exhibitors unless arranged otherwise with the Gallery. The Gallery does have bar staff contacts it can provide to exhibitors.

Please inform us and obtain our pre-agreement before the start of your exhibition relating to any other functions or meetings you plan to hold during the opening hours of your exhibition.

### **Storage and shipping for commission shows.**

Unless pre-agreed otherwise by the Gallery, the exhibitor is responsible for delivering all artworks to the Gallery and the exhibitor is also responsible for all artworks being picked up / removed from the Gallery (including all purchased works) before the end of the exhibition. If purchased works have not been picked up by purchasers by the end of the exhibition, the exhibitor must please remove the works at the end of the exhibition, unless pre-agreed otherwise in writing by the Gallery. The exhibitor is solely responsible for the delivery (including any packaging materials, other kinds of work and all costs associated with delivery to purchasers) of all artworks purchased. Any storage in the Gallery's premises after the end of any exhibition, is subject to the Gallery's express written pre-agreement and is at the Gallery's sole discretion and is dependent on availability of storage space and may be subject to a further charge.

### **Gallery 'manning' during the exhibition period.**

Exhibitors are very welcome and are encouraged to invigilate / be in attendance at all times during their exhibitions. The Gallery is sometimes able to provide one member of its team to open the Gallery, invigilate, handle sales and close the Gallery Monday - Friday, if exhibitors are unavailable.

No members of the Gallery team are present on Saturdays and Sundays and the Gallery is closed on these days unless exhibitors wish to open the Gallery and invigilate themselves. The Gallery can provide a portable desk, chair and free Wi-Fi. There are some additional chairs available upon request for visitors.

### **Gallery keys**

Please note that exhibitors must collect the keys to the Gallery in person during working hours 3 – 5 working days before start of exhibition. Please contact the Gallery to arrange a time. At the time of the key hand-over exhibitors are given a guided tour of the Gallery and its systems and asked to sign a written copy of an Exhibitor Code of Conduct guide which includes an insurance related undertaking (this undertaking is also included later in this document – see the heading below entitled "Insurance"). The keys must be returned by the exhibitor in person to the Gallery no later than the Wednesday of the following week after your exhibition ends. Key return by post or courier is not acceptable for security reasons and all key returns must be 'by hand' in person into the hands of a Gallery team member during Gallery working hours of 9.45am – 5.45pm Monday – Friday



### **Setting up/taking down of the exhibition**

Exhibitors may enter the Gallery from 8am on Sunday to hang work. They must please vacate the premises by 9pm on the closing Saturday having first tidied the Gallery, cleaned any areas that may have got dirty and also having left any refuse in Camden bin bags at the foot of the lamp post that is located 10 metres or so to the right hand side of the Gallery front door (the right hand side as one looks out from the front door to the street). This is the only spot that Camden Council authorises the Gallery to leave its rubbish. The Gallery provides the required Camden Council rubbish bags free-of-charge. No noise please after 8pm, as it is a residential area. Due to health and safety regulations, no work is permitted to be exhibited on or against the heating vents around the Gallery. All work must be taken down and removed and the Gallery must be left as found and cleaned and cleared of all mess by 9pm on the last Saturday of the agreed exhibition period.

The Gallery has very limited storage facility - so all exhibitors must hang their work immediately on arrival in the Gallery and must also remove all works (including purchased works) by 9pm on the last day of the exhibition, unless pre-agreed otherwise in writing with the Gallery.

### **Confirmation of booking and payments.**

A binding contract between the Gallery and exhibitor is formed once this document and the Exhibitor Code of Conduct document have been supplied to the exhibitor and the exhibitor has subsequently made his/her/its initial booking confirmation payment.

If you are hiring the space and do not want to use our card payment facility, you are welcome to bring your own card machine and it is your sole responsibility to take care of securing all payments (all such to be made payable to a beneficiary other than the Gallery). The staff cannot accept cash for any artworks or merchandise on display in the Gallery. We will however accept cheques payable to the exhibitor if you are not in attendance.

**Press release re-wording, price lists and Visitor books.**

The Gallery will provide up to 1 hour free-of-charge assistance (only if required) to re-write or edit and finalise a first draft text document supplied to it by exhibitors and to send a finalized Press Release to arts journalists and to invite selected invitees to a Private View. Additional time will be subject, potentially, to an additional charge by the Gallery at the rate of £40 + VAT per hour.

All exhibitors are required, please, to supply a first draft Press release to the Gallery (via email in editable Word doc format) for consideration.

If you are hiring the space, please produce your own price lists and/or wall mounted price signage (white tac only is allowed or Avery non-sticky address labels - details below)

Avery Labels – Avery Software Code Ref No: J8565 - Clear Inkjet labels (these are transparent/clear cell). 8 labels per sheet. Sheet size: 99.1mm x 67.7mm. Available online but not from Viking or Staples. Available from Avery at [www.avery.eu](http://www.avery.eu)

The Gallery cannot design, write or print your price lists, unless absolutely necessary. In such circumstances, we may print up to 50 B&W copies only.

**Visitor Book.**

The Gallery will supply its Visitor Book which is please to be used re: all visitors and on the understanding that information from the Visitors Book may be used in future by the Gallery to invite attendees to future exhibitions. The Gallery will supply each exhibitor with scans of all Visitor Book entries during the exhibitor's exhibition. If, for any reason, an exhibitor prefers to use their own Visitor Book the exhibitor undertakes either to permit the Gallery to photocopy or scan all entries from the exhibition or to provide photocopies or scans promptly to the Gallery within 5 days of end of exhibition and for the Gallery to contact any individuals regarding future exhibitions.

### **Drinks.**

If you are hiring the space, you are responsible for arranging drinks, glasses and ice for your exhibition. We recommend our local and long-standing wine merchant, Nicolas Ltd, [www.nicolas.co.uk/store-finder/great-portland-street/](http://www.nicolas.co.uk/store-finder/great-portland-street/) or our local Tesco Metro which is 200 yards from the Gallery and which permits drinks to be 'trundled' here in one its shopping trolley's subject to the person borrowing the trolley leaving a driving licence or credit card until the trolley is returned. Please let us know what you plan at least 10 working days in advance, so that we can organise delivery times. You are expected please to help set up and clear away all drinks and waste on the night of your Private View. Any refuse/waste must be placed in Camden bin bags at the foot of the lamp post that is located 10 metres or so to the right of the Gallery front door as one looks out from the front door to the street. This is the only spot that Camden Council authorises the Gallery to leave its waste. The Gallery provides the required Camden Council refuse bags free-of-charge. All drinks are usually served in the lower ground floor

Gallery and any left over drinks must be removed at the end of your exhibition. If you have organised drinks but do not have glasses, Capital Hire can hire and clean 100 glasses for around £24: [www.capitalhire.com](http://www.capitalhire.com). Alternatively the Gallery has around 120 wine glasses available free-of-charge. Cleaning of these glasses is the responsibility of the exhibitor and such cleaning must be carried out during the exhibition. However, subject to workload, the Gallery team may assist with glass cleaning. The Gallery has a dishwasher in its 1st Floor office.

We have two large ice buckets here at the Gallery (they will hold all wine bottles and beers). Any bar staff or outside help must adhere to the conditions of hiring the Gallery. Alcohol must not be sold on the premises

**Waste.**

All rubbish must be tied up in Camden Council purple refuse bags at the foot of the lamp post 10 yards to the right hand side of the Gallery front door (to the right hand side of the front door as one looks out to the street from the front door). No rubbish may be left out before 4pm on any day. (The Gallery has a limited supply of refuse bags but will endeavour to supply at least two to the exhibitor. Otherwise all refuse must be taken away by the exhibitor.

**Charges.**

Accidentally or otherwise, any damage to the Gallery and its contents, loss of utility of Gallery property or failure to comply with this document's other terms, may regrettably result in potential claims against the exhibitor.

**Maintenance.**

The Gallery must be left neat and tidy, with all rubbish and materials removed after hanging and taking down your artwork. There are to be no marks remaining on any of the Gallery surfaces. All three Gallery floors must be swept if necessary and, also if necessary, mopped with hot water before leaving the Gallery. A mop and bucket is sited in the toilet. A supplementary charge invoice will be issued if the Gallery's Conditions of Hire standards are not met. You may be subject to a storage charge fee for any work left in the Gallery.

**Security.**

For security and insurance purposes, a member of staff may be in attendance during the Private View evening. It is the responsibility of the exhibitor to ensure that the front door is monitored or kept shut if no member of the Gallery team is present on the Gallery floor, especially on Saturday and Sunday when hanging or take down work. If the front door is shut, visitors can ring the doorbell to the side of the door and someone will let them in.

The Gallery is not responsible for any personal property going missing eg. money, wallets, bags, mobile phones etc. It is essential that exhibitors ensure that all windows and doors are locked and the alarm is set when leaving the property. All lights and the heating must also be turned off.



**Insurance.**

Artwork shall remain at your sole risk while the artwork is in the possession of the Gallery. During the packing, transport and display of the artwork at or to the Gallery, you shall at your own expense, obtain and maintain the following insurances: (i) insurance of the artwork to a value not less than its full replacement value comprehensively against all usual risks of loss, damage or destruction by fire, theft or accident, (ii) insurance for such amounts as a prudent owner of the artwork would insure for, or such amount as The Gallery may from time to time reasonably require, to cover any third party or public liability risks of whatever nature and however arising in connection with the artwork, and (iii) insurance against such other or further risks relating to the artwork as may be required by law.

You shall, on reasonable notice, supply copies of the relevant insurance policies or other insurance confirmation acceptable by the Gallery and proof of premium payment to the Gallery to confirm the insurance arrangements.

For the avoidance of doubt, the Gallery shall not provide any insurance coverage for the artwork and shall not be liable to you for any for: (i) any loss of, or damage to, the artwork, (ii) claim for loss of publicity or opportunity to enhance your reputation.

**Force Majeure**

The Gallery shall not be in breach of this Agreement or otherwise liable for any failure or delay in the performance of its obligations if such delay or failure results from events, circumstances or caused beyond its reasonable control, including but not limited to acts of God, flood, fire, or other natural disaster, epidemic or pandemic, any law or any action taken by a government or public authority, the Coningsby Gallery shall be entitled to a reasonable extension of its obligations. You acknowledge that the Coningsby Gallery shall have no liability with respect to any loss incurred by you caused by the Gallery's service providers or any party outside of the Gallery's control.

**Liability.**

The restrictions on liability in this section apply to every liability arising in connection with the contract including liability in contract, tort (including negligence), misrepresentation, restitution, deliberate fault or otherwise.

Nothing in the contract limits any liability which cannot legally be limited, including liability for: (a) death or personal injury caused by negligence; and (b) fraud or fraudulent misrepresentation.

Subject to the above, our total liability to the exhibitor shall not exceed the fees paid.

## Gallery Directions and Information

The Coningsby Gallery

30 Tottenham Street

London W1T 4RJ

United Kingdom

07884 314361

[www.coningsbygalleries.com](http://www.coningsbygalleries.com)

**Enquiries:** [info@coningsbygalleries.com](mailto:info@coningsbygalleries.com)

### Opening hours.

Weekdays: 9.00am – 6.00pm. The Gallery is closed on weekends, unless pre-agreed with the exhibitor. Exhibitors may or may not open the Gallery at weekends, at their discretion.

### Parking.

Parking on single yellow lines and in the residential parking bays on Tottenham Street is permitted from 6.30pm on Saturdays until 8.30am on Mondays. Parking in the residential parking bays on Tottenham Street is also permitted on weekdays from 6.30pm – 8.30am. One residential bay on Tottenham Street is within 10 yards of the Gallery, the other is circa 50 yards. Loading and unloading for up to 20 minutes from double yellow lines on Tottenham Street is permitted on any day.

There is usually a high availability of parking spaces (Pay and Display Machine Parking) in bays on Whitfield Street and Charlotte Street throughout Saturdays and Sundays. There are a few such bays located within 150 yards of the Gallery. There is an NCP car park on Cleveland Street (circa 400 yards from the Gallery) and another on Tottenham Court Road (circa 800 yards from the Gallery).

Pay and Display information: Maximum stay is 2 hours. 40p per 5 minutes, Monday – Saturday, 8.30am – 6.30pm.

London Borough of Camden parking enquiries and assistance:  
+44 (0)20 7974 5543

### **Tube.**

The Gallery is located 250 yards from Goodge Street Underground station (which is on the Northern Line). Turn left out of Goodge Street station, take the first road on the left (Tottenham Street, London W1). Walk 200 yards along Tottenham Street on the right hand side of the road when walking from Goodge Street station. The Gallery is located on this side of the road at 30, Tottenham Street. Warren Street, Tottenham Court Road and Oxford Street Underground stations are also within 5 – 6 minutes walk.

### **Bus.**

10\*, 14\*, 24\*, 29, 73, 134\* and 390\*

\*24 hour service

### **Taxis.**

Taxis can be easily hailed from Tottenham Court Road. It is a one way street, which heads north towards Warren Street Tube. Alternatively, a local taxi service can be called. Cheap taxis in London can be reached on +44 (0)20 7118 8888 or Taxi W1 on +44 (0)207 407 333

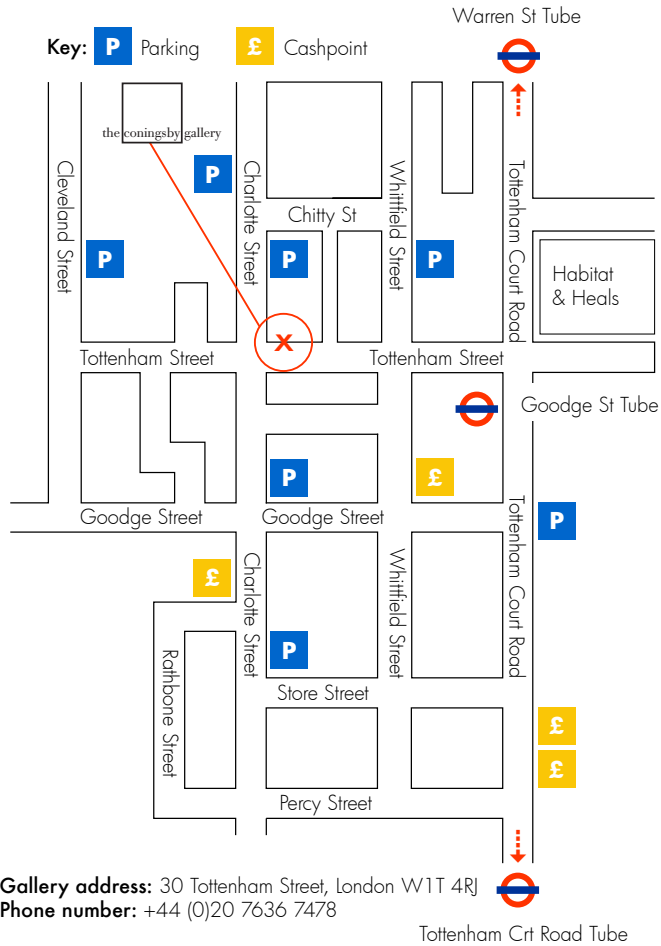

Signed by artist.....

Date.....

**THANK YOU. PLEASE ENSURE THAT YOU HAVE READ EVERYTHING IN THIS DOCUMENT CAREFULLY.**